

About the process

---

## AQUABOX HP

---

**Product family/Process:** Rainwater storage process**Holder(s) :** GEOPLAST S.P.A.

### FOREWORD

Technical opinions and technical application documents, hereinafter referred to interchangeably as Technical Opinions, are intended to provide those involved in the construction industry with **information on the suitability for use of products or processes** whose construction or use is not covered by traditional know-how and practices.

The resulting document should be considered as such, and is **not a document of compliance with regulations or a "quality mark"**. Its validity is determined independently of that of the supporting documents in the technical file (in particular, any regulatory certificates).

The Avis Technique is a voluntary initiative on the part of the applicant, and in no way alters the division of responsibilities between those involved in the construction process. Irrespective of whether or not a Technical Approval has been issued, all parties involved in the construction process are required to provide or request the necessary supporting documents, depending on their role.

As the Avis Technique is intended for parties deemed to be familiar with the rules of the art, it is not intended to contain any information other than that relating to the non-traditional nature of the technique. Thus, for aspects of the process that comply with recognized rules of the art for installation or dimensioning, a reference to these rules is sufficient.

**Groupe Spécialisé n° 17.2 - Réseaux et épuration / Networks**



## Document versions

Version	Description	Reporter	Chairman
V1	First version of the Avis Technique.	LAKEL Abdel Kader	VIGNOLES Christian

### Descriptor :

The AQUABOX HP retention and infiltration system is made from polypropylene modules and various components assembled on site. These modules can be juxtaposed or stacked to form a reservoir for rainwater.

A clear space between the columns making up the structure allows the passage of operating equipment.

A range of accessories is available for hydraulic connections, basin ventilation and end-face sealing.

The main features of AQUABOX HP modules are as follows:

- Color: black,
- Length: 750 mm,
- Width: 750 mm,
- Height: 800 mm.

This opinion is formulated taking into account the manufacturing controls and verification procedures supplied with the instruction and verified by GS 17.2.

## Table of contents

1.	Opinion of the Specialized Group .....	4
1.1.	Accepted area of use.....	4
1.1.1.	Geographical area .....	4
1.1.2.	Targeted works .....	4
1.2.	Assessment.....	4
1.2.1.	Process suitability.....	4
1.2.2.	Durability.....	4
1.2.3.	Environmental impact .....	5
1.3.	Additional comments from the Specialized Group .....	5
2.	Technical File .....	6
2.1.	Marketing methods.....	6
2.1.1.	Contact .....	6
2.1.2.	Identification .....	6
2.1.3.	Marketing methods .....	6
2.2.	Description .....	6
2.2.1.	Principle.....	6
2.2.2.	Component features.....	7
2.2.3.	Appearance, finish.....	7
2.2.4.	Dimensions.....	7
2.2.5.	Mass .....	7
2.2.6.	Mechanical characteristics of modules.....	7
2.3.	Design provisions .....	8
2.3.1.	Geological and hydrological environment .....	8
2.3.2.	Volumes.....	8
2.3.3.	Mechanical behavior.....	9
2.3.4.	Hydraulics .....	9
2.4.	Packaging, handling, storage.....	10
2.4.1.	Packaging.....	10
2.4.2.	Handling.....	10
2.4.3.	Storage .....	10
2.5.	Implementation provisions .....	10
2.5.1.	Earthmoving operations.....	10
2.5.2.	Module installation .....	10
2.5.3.	Ventilation.....	11
2.6.	Product or process maintenance.....	12
2.6.1.	Access to the book .....	12
2.6.2.	Care and maintenance.....	12
2.7.	Principles of manufacturing and manufacturing control.....	12
2.7.1.	Manufacturing process.....	12
2.7.2.	Internal controls.....	12
2.7.3.	External controls .....	12
2.8.	Mention of supporting documents.....	12
2.8.1.	Experimental results .....	12
2.8.2.	Project references.....	13
2.9.	Technical File Appendix.....	14

# 1. Opinion of the Specialized Group

The process described in Chapter 2 "Technical File" below has been examined by the Specialized Group, which has concluded that it is suitable for use under the conditions defined below:

---

## 1.1. Accepted areas of use

---

### 1.1.1. Geographical area

The notice was formulated for use in mainland France and the French overseas departments and regions (DROM).

### 1.1.2. Targeted works

AQUABOX HP modules are designed for the creation of in-ground basins, under the conditions defined in the Technical File, in order to allow :

- rainwater retention when the structure is encased in a waterproof geomembrane,
- or infiltration into the supporting soil when the structure is not designed to be

watertight. Please note that :

- AQUABOX HP modules must never be located in flood-prone areas,
- the presence of an outlet is mandatory: overflow and connection to a rainwater drainage system.

---

## 1.2. Assessment

---

### 1.2.1. Process suitability

The present Notice is formulated in the light of the written undertaking by the holder to comply with regulations, and in particular with all regulatory obligations relating to products which may contain hazardous substances, for their manufacture, their integration into works in the accepted field of use and the operation of such works. Control of information and declarations issued in application of the regulations in force does not fall within the scope of the present notice. The holder of the present notice retains full responsibility for such information and declarations.

AQUABOX HP Ultra Lightweight Alveolar Structures and their implementation comply with the recommendations of the Technical Guide "Ultra Lightweight Alveolar Structures (SAUL) for rainwater management (2011)".

The tests or studies carried out by the applicant or by CSTB, together with the references supplied, show that this product is suitable for the field of use envisaged in § 1.1.

Compliance with the design and installation conditions defined in the Technical Dossier is essential for the system to function properly.

The useful volumes of the structures used limit the amount of earthwork required. Modular design enables adaptation to the topographical constraints of the structure.

### 1.2.2. Durability

#### 1.2.2.1. Material

Given the nature of the constituent materials, component durability poses no particular problem.

#### 1.2.2.2. Access conditions

Access conditions as defined in the Technical File are satisfactory. Access must be via inspection boxes or manholes located upstream and downstream of the structure.

#### 1.2.2.3. Durability of functions

Ultra-light honeycomb structures cannot be completely cleaned. Only the channels (space between the piles) connected to the manholes, and only via a DN 200 inlet cut into the lower part of the side plate, can be cleaned more or less completely.

The installation of an upstream treatment system reduces the frequency of maintenance operations and ensures the long-term operability of the storage facility.

The characteristics of the stormwater (presence of macro-waste, dead leaves, etc.) must be taken into account when defining access conditions, distribution channels and the nature of pre-treatment.

The expected functions of the structure depend on compliance with maintenance conditions.

Manholes, inspection boxes and channels must be inspected and, if necessary, cleaned after heavy rainfall or accidents, at a frequency appropriate to site conditions. Maintenance operations should be adapted according to the results of these inspections.

In the case of infiltration structures, compliance with the project study approach defined in § 3 of the SAUL guide (nature of effluent, soil characteristics, etc.) and maintenance conditions are imperative to ensure that infiltration capacity is maintained over time.

Subject to compliance with design rules and maintenance conditions, the storage volume of the structure is considered to be maintained over time.

### **1.2.3. Environmental impact**

There is no Environmental Declaration (ED) for this product.

In particular, data from EDs are used to calculate the environmental impact of structures in which the products (or processes) in question are likely to be integrated.

Please note that this ED does not fall within the scope of the product's fitness-for-use test.

---

### **1.3. Additional comments from the Specialist Group**

---

Specialist Group No. 17 draws the designer's attention to :

- the importance of protecting these structures from the introduction of settleable matter,
- the constraints associated with cleaning operations. In particular, the choice of hydrocleaning tools must be checked to ensure that they are compatible with the characteristics of the products.
- accessibility and cleaning only via DN 200 connections (cut-out DN 200 template at bottom of side plate).
- ventilation only via connections to manholes fitted with ventilated plugs; DN 200 connections (cut out DN 200 template at top of side plate).

## 2. Technical File

Based on information supplied by the contractor and the specifications of the Specialized Group accepted by the contractor.

---

### 2.1. Marketing methods

---

#### 2.1.1. Contact

Owner: GEOPLAST 6 Via  
 Martiri Della Liberta IT -  
 35010 GRANTORTO Tel:  
 +39 0499490289  
 Email: geoplast@geoplastglobal.com  
 Internet: www.geoplastglobal.com

Plant: IT - 35010 GRANTORTO

#### 2.1.2. Identification

Each module includes the following information, in accordance with the QB brand standards:

- the name: AQUABOX HP,
- plant identification,
- the material (PP),
- date of manufacture (year, month),
- the QB logo followed by the reference shown on the certificate.

#### 2.1.3. Marketing methods

AQUABOX HP modules and accessories are marketed through a network of distributors.

---

### 2.2. Description

---

#### 2.2.1. Principle

AQUABOX HP products fall within the scope of structures as defined in the Technical Guide « Les structures alvéolaires ultra légères (SAUL) pour la gestion des eaux pluviales » (Ref. IFSTTAR, Edition 2011).

AQUABOX HP modules are designed in accordance with NF EN 17152-1 to create underground basins for optimizing stormwater runoff management in public works and civil engineering.

They feature a mechanical structure with vertical, pyramid-shaped piles, enabling them to be interlocked and limiting the volumes transported.

AQUABOX HP modules and accessories can be used to perform the following functions:

##### **Service functions :**

The service functions provided by structures built using AQUABOX HP modules are storage and/or infiltration.

Rainwater retention is ensured when the structure is encased in a waterproof geomembrane. When the structure is not designed to be watertight, infiltration can take place into the supporting soil.

##### **Technical functions :**

The technical functions provided by structures built using AQUABOX HP are as follows:

##### *Collection and Restitution :*

These two functions are carried out by means of ancillary components, including manholes (or inspection boxes) implemented on the periphery) and interface parts.

In the case of a watertight structure, the discharge flow rate depends on the rate of filling of the sump of the internal diameter of the connection to the discharge network, or is regulated by means of a suitable device.

##### *Structural :*

The structural nature of the modules means that the surface can still be used.

##### *How to find us :*

Access to the structure is via manholes (or inspection boxes) on the periphery of the structure.

For inspection and cleaning, only channels connected to manholes and via a DN 200 inlet (DN 200 template cut-out at bottom of side plate) are accessible.

**Ventilation :**

The structure must enable air pressure to be balanced during filling and emptying phases. To achieve this, the total cross-sectional area of the aeration tubes must be at least 100% of the total cross-sectional area of the water inlet pipe(s).

**2.2.2. Component features**

A work made from AQUABOX HP products consists of :

- AQUABOX HP modules (80 cm high) made up of 2 half-modules assembled on site by interlocking.
- Connectors to ensure correct stacking (double connectors) and juxtaposition (single connectors) of modules.
- HP side plates, to close the sides of the modules, with cutting templates for connecting pipes from DN 100 to 500.
- HP top plates, to close the top of the basin: four plates per module.

Modules, side plates and top plates are made of recycled, glass-fiber-reinforced polypropylene. Connectors are made from recycled polypropylene.

**2.2.3. Appearance, finish**

The internal and external surfaces of the modules are smooth and free from cracks. The modules are black in color.

The plates are black.

Connectors are red.

**2.2.4. Dimensions**

The modules have the following nominal dimensions:

- Length:  $750 \pm 3$  mm,
- Width:  $750 \pm 3$  mm,
- Height:  $800 \pm 3$  mm.

Plate and connector dimensions are given in the appendix. Piles have a wall thickness of 3.5 mm.

The useful volume of an AQUABOX HP module is 432 liters. This value is determined by calculation.

**2.2.5. Mass**

The weight of the AQUABOX HP module is  $18 \text{ kg} \pm 0.4 \text{ kg}$ .

The HP side plate weighs  $2.4 \text{ kg} \pm 0.2 \text{ kg}$ .

The weight of the HP top plate is  $0.33 \text{ kg} \pm 0.03 \text{ kg}$ .

**2.2.6. Mechanical characteristics of modules****2.2.6.1. Short-term characteristics****2.2.6.1.1. Simple compressive strength**

Simple compressive strength is determined in accordance with NF EN 17150 in three directions (x, y, z) on AQUABOX HP modules.

The measured characteristics are as follows:

Features	Specifications		Test parameters
	Minimum stress at break	Strain at maximum stress	
- Y and X on side panels (750 x 800 mm)	100 kN/m <sup>2</sup>	≤ 2%	Method A - constant rate of stress (0.50 ± 0.05) kN/m <sup>2</sup> /s = 0.50 ± 0.05 kN/m <sup>2</sup> /s = 0.50 ± 0.05 kN/m <sup>2</sup> /s 30 kPa/min
- Z on top (750 x 750 mm)	400 kN/m <sup>2</sup>	≤ 2%	

**2.2.6.1.2. Vertical compression on stacked modules**

Type tests carried out in accordance with NF EN 17150 (Method A) on 2 floors of modules showed an average vertical compressive breaking load (for a test speed of 0.5 kN/m<sup>2</sup>/s) of 429 kPa.

### 2.2.6.1.3. Effect of a 1% slope on vertical resistance

Type tests carried out in accordance with NF EN 17150 (Method A) show that a 1% slope of the subgrade has no impact on short-term strength in the vertical direction of the modules.

### 2.2.6.1.4. Sensitivity to a non-rigid load

Type tests were carried out in accordance with Annex A of NF EN 17152-1. The average strength did not decrease by more than 25% compared with the average short-term compressive strength in the vertical direction, in accordance with NF EN 17152-1.

### 2.2.6.2. Long-term characteristics

Fracture tests were carried out between two rigid trays, at different stress levels to enable a stress vs. log time curve to be established, in accordance with the protocol in standard NF EN 17151.

The breakdown of breakpoints is as follows:

- From 100 to 500 hours: 4 breakpoints,
- From 500 to 1000 hours: 3 breaking points,
- From 1000 hours to 2000 hours: 1 breakpoint,
- From 2000 to 4380 hours: 1 breakpoint,
- Over 4,380 hours: at least 1 breakpoint.

#### 2.2.6.2.1. Long-term admissible vertical load

The maximum vertical stress that would lead to module failure after 50 years in service is estimated at 109 kPa, integrating the 95% confidence limit, with a corresponding deformation of 1%.

#### 2.2.6.2.2. Long-term admissible horizontal load

The maximum horizontal stress that would lead to module failure after 50 years in service is estimated at 23 kPa, integrating the 95% confidence limit, with a corresponding deformation of 1.4%.

---

## 2.3. Design provisions

---

The information provided must make it possible to characterize the conditions under which the structure will be installed, the conditions under which it will be built (available right-of-way, earthwork method, specific constraints, etc.), and the operating conditions (rolling loads, permanent loads, occasional instantaneous loads, etc.).

It should be emphasized that the information contained in these technical studies is intended as a design aid. They must enable the project manager to carry out the necessary dimensioning and validation, which are his responsibility.

During the construction phase, the surface above the structure must not be used for any purpose other than that specified in the design phase (e.g. storage of spoil).

In the case of seepage basins: a minimum distance of 5 m must be maintained between the seepage basin and the right-of-way of any surrounding foundations. In the case of shallow foundations (deep foundations are not affected, e.g. pile foundations), these must always be located above the slope with a gradient of 33% (1V/3H) from the lowest point of the infiltration basin closest to the shallow foundation building towards the deeper soil horizons (foundation side).

These distances and plans take into account the mechanical (additional load) and hydraulic risks that could be induced by the infiltration basin near founded structures.

Any exception to this rule must be the subject of a specific study by an engineering firm, taking into account the risk to the building and the infiltration basin.

### 2.3.1. Geological and hydrological environment

The geological and hydrological environment in which the project will be implemented must be studied. The hydrological study will include the EH and EE water levels in all cases, with EH the water level corresponding to a fifty-year return period and EE the exceptional water level.

In the case of infiltration basins, soil permeability will also be taken into account. In the case of watertight basins, empty stability must be studied.

The useful volume of the basin is determined by the project manager.

### 2.3.2. Volumes

The volume of the basin is determined by the project manager in accordance with the Technical Guide "Les Structures Alvéolaires Ultra Légères (SAUL) pour la gestion des eaux pluviales-2011- IFSTTAR".

#### 2.3.2.1. Excavation volume

The excavation volume is determined by the project manager in accordance with the Technical Guide "Les Structures Alvéolaires Ultra Légères (SAUL) pour la gestion des eaux pluviales-2011- IFSTTAR" (§5.2).

### 2.3.2.2. Useful volume

The useful storage volume is determined by the project manager in accordance with the Technical Guide "Les Structures Alvéolaires Ultra légères (SAUL) pour la gestion des eaux pluviales". It must take into account :

- Useful volumes of AQUABOX HP modules,
- The water level at the outlet.
- The slope of the subgrade in the case of a watertight structure. The slope of the subgrade is generally 0.5% and must be less than 1%.
- From the water level of the ventilation pipe: 250 mm above the pool roof.

In the case of a retention structure, the net volume of the structure is reduced by the volume between the bottom of the basin and the outlet water level. The height between the bottom of the basin and the outlet water level is :

Connection DN	Height from pond bottom to outlet water level
100 mm	375 mm
110 mm	370 mm
125 mm	362.5 mm
160 mm	345 mm
200 mm	325 mm
200 mm off-center (at bottom of plate)	50 mm
225 mm	312.5 mm
250 mm	300 mm
315 mm	267.5 mm
400 mm	225 mm
500 mm	175 mm

### 2.3.3. Mechanical behavior

Sizing is carried out by the project manager in accordance with the guide "Les Structures Alvéolaires Ultra Légères (SAUL) pour la gestion des eaux pluviales" (December 2011).

The project manager's calculation note must take into account :

- the height and type of fill,
- type of traffic,
- any static loads (storage, fireman's skid support, etc.),
- the dimensions of the structure,
- long-term module strength and deformation,
- the presence of groundwater for retention structures.

The basin can be installed under pavements, parking lots, sidewalks, verges and green spaces, subject to a minimum cover height of :

- under green spaces, with a minimum cover height (Hr) of 0.30 m.
- under light vehicle parking with  $Hr \geq 0.50$  m,
- under heavy traffic (BC convoy type) with  $Hr \geq 0.80$  m.

Knowing and taking into account the geotechnical characteristics of the soil is essential for the design and construction of the structure.

To ensure the stability of the structure and its compatibility with possible road applications, it is imperative to comply with the provisions recommended by the project manager at the preliminary design stage and submitted to the manufacturer, depending on the specific case of the site.

It should be remembered that the maximum permissible long-term deformation of the structure is to be set by the project manager. This requirement may limit the number of admissible layers, independently of other considerations. The long-term deformation value to be taken into account is 0.5% of the total height of the modules.

Installation in the presence of groundwater must be subject to special checks as defined in the Technical Guide. Particular attention should be paid to the means used to ensure the load-bearing capacity of the underlying soil.

The overall safety coefficient used for sizing will be 2.5, corresponding to a  $\gamma_A$  of 1.35 and a  $\gamma_M$  of 1.85, i.e. an overall coefficient of 2.5.

When the structure is built under a roadway, the dynamic effects will be taken into account under the conditions of Fascicule 70.

### 2.3.4. Hydraulics

Provisions for calculating infiltration rates into the ground, sizing structures and general constructive provisions are defined in the Technical Guide "Les structures Alvéolaires Ultra Légères (SAUL) pour la gestion des eaux pluviales (2011)" and in Fascicule 70 Titre II.

Long-term hydraulic performance depends on proper maintenance.

---

## **2.4. Packaging, handling, storage**

---

### **2.4.1. Packaging**

AQUABOX HP modules are delivered on pallets of 80 stacked half-modules. Side and top plates are delivered stacked on pallets.

Connectors are supplied in bags of 400 (single connector) or 300 (double connector).

### **2.4.2. Handling**

Loading and unloading pallets is not particularly difficult. The precautions for using a forklift truck must be observed to avoid damage to the parts. Avoid rough handling and falling on the floor during unloading.

### **2.4.3. Storage**

Pallets must be stored on flat surfaces, free from any object that could damage the products. The maximum outdoor storage period is one year.

---

## **2.5. Implementation provisions**

---

### **2.5.1. Earthmoving operations**

The following operations are carried out in accordance with the minimum requirements of the Technical Guide "Les structures alvéolaires ultralégères (SAUL) pour la gestion des eaux pluviales (IFSTTAR, 2011)" (§5):

- Earthworks and preparation of subgrade,
- Geotextile and waterproofing characteristics and application,
- Lateral backfilling,
- Initial backfill and subgrade.

In all cases, the installation plans and locations defined by the project manager must be respected.

#### **Special features :**

Once the geosynthetic has been applied :

- Place a protective layer of gravel about 15 cm thick.
- Place a first layer of backfill.
- Do not drive directly over the modules or the protective layer.
- Backfill over the basin by advancing from the sides of the structure in compacted layers of 30 cm (first layer with D<32mm material).
- Use light tracked machines to spread the backfill (maximum load 50 kN/m<sup>2</sup>).
- The first layer is compacted using vibrating plates with a working weight of 300 kg. Vibratory rollers may not be used.
- The use of compaction equipment for subsequent layers is limited to a total weight of 6 tonnes.

### **2.5.2. Module installation**

The elements set out below are only those that complete the application of the minimum requirements of the Technical Guide "Ultra-lightweight honeycomb structures (SAUL) for stormwater management".

#### **2.5.2.1. Preparation**

Carefully unload the various components from the pallets.

Remove the connectors to be associated with the various components from the packaging bags.

#### **2.5.2.2. Module assembly**

A module corresponds to the assembly of two half-modules. Once clipped together, the 2 half-modules are permanently assembled. Modules are linked by single and double connectors.

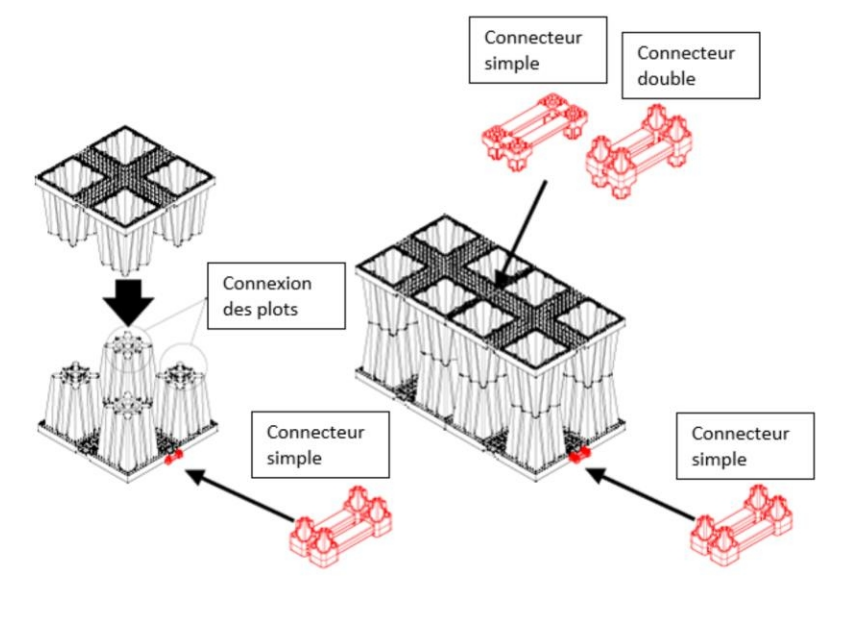

### 2.5.2.3. Module installation

Two juxtaposed modules must be connected to each other by :

- A double connector, if the modules are not on the upper level of the basin,
- A single connector for the modules on the upper level of the basin.

The side plates are clipped onto the various sides of the pool.

Once the top floor has been laid, close the openings in the roof of the basin (at pile level) with the top plates (4 plates per module).

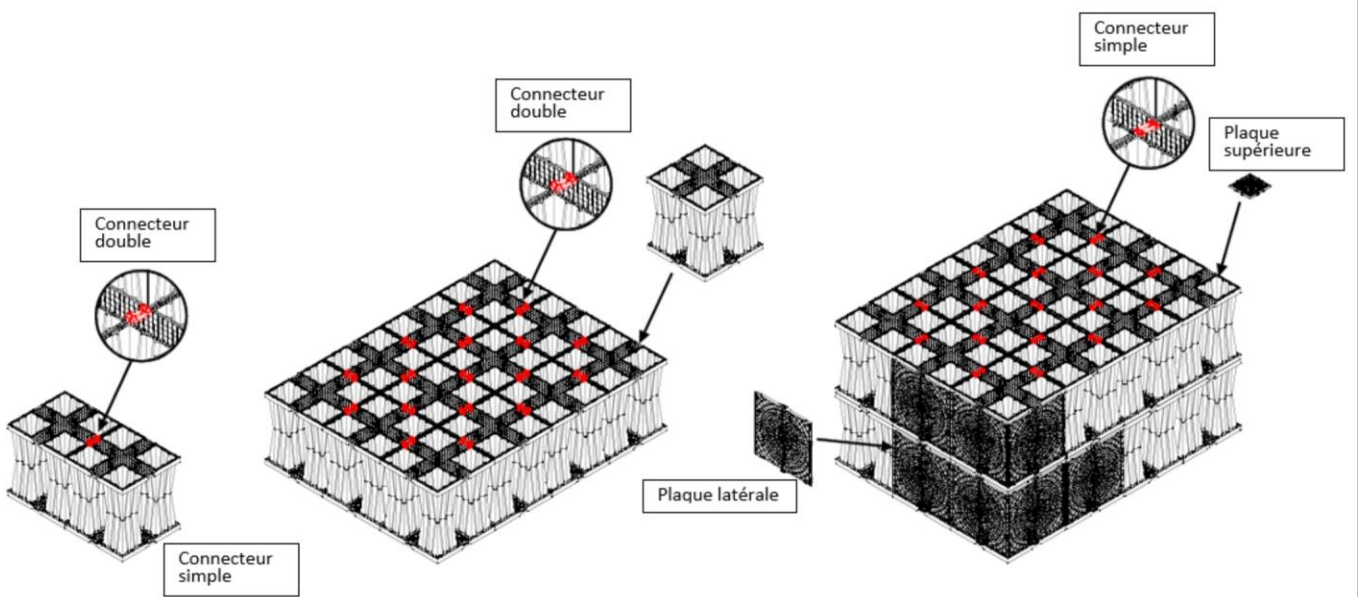

### 2.5.2.4. Connecting the basin to the network

To connect the pool to the mains, the side plate must be cut (using a jigsaw or hand saw) to the diameter of the pipe to be connected, before clipping the plate onto the module.

Install the drilled plate on the pond. The geotextile and geomembrane (if applicable) are then drilled through the plate to allow the pipe to pass through.

### 2.5.3. Ventilation

Ventilation must be carried out using DN/OD 200 sanitation pipes with smooth outer walls and annular rigidity compatible with the constraints of the project.

The number of vents depends on the total cumulative cross-sectional area of the water supply pipes (cross-sectional area of the vent(s) = 100% of the cross-sectional area of the inlet manifold(s) connected to the basin).

The pipes are installed around the periphery of the basin, laterally on the upper level. The DN 200 cutting jig, eccentrically located at the top of the side plate, is cut out for connection. The pipes lead into manholes fitted with ventilated plugs.

---

## 2.6. Product or process maintenance

---

The general conditions of maintenance and operation of the structures are carried out in accordance with the Technical Guide "Ultra-lightweight honeycomb structures (SAUL) for stormwater management" (§7).

As a general rule, it is advisable to install a filtration and/or decantation system upstream of the facility, which will be cleaned at a frequency that depends on the nature of the pre-treatment equipment and the environment.

### 2.6.1. Access to the book

The basin is connected to a manhole or inspection box (Dint  $\geq$  600 mm) using standard DN 100 to 500 pipes.

For inspection and cleaning, only channels connected to manholes and via a DN 200 inlet (DN 200 template cut-out at the bottom of the side plate) are accessible.

### 2.6.2. Care and maintenance

The general conditions of maintenance and operation of the structures are carried out in accordance with the Technical Guide "Ultra-lightweight honeycomb structures (SAUL) for stormwater management" (§7).

As a general rule, it is recommended to install a filtration and/or decantation system upstream of the structure, which will be cleaned at a frequency that depends on the nature of the pre-treatment equipment and the environment.

A televisual inspection, at least every 2 years, and after special events (exceptional rainfall, work near the basin, etc.) is recommended to check the functional integrity of the structure.

Pre-treatment reduces the frequency of maintenance operations.

Accessible channels are cleaned at a maximum pressure of 120 bar and a maximum cleaning flow rate of 250 L/s. Cleaning must be carried out by hydrocuring only, with no additional mechanical action.

---

## 2.7. Principles of manufacturing and manufacturing control

---

### 2.7.1. Manufacturing process

AQUABOX HP products are manufactured by injection molding at the Grantorto site.

### 2.7.2. Internal controls

The production plant's quality system is certified ISO 9001 (version 2015).

The nature and frequency of checks on raw materials, the manufacturing process and finished products are filed with the CSTB.

### 2.7.3. External controls

AQUABOX HP products are certified by the QB mark, which attests to the regularity and satisfactory outcome of internal controls. Products with a valid certificate are identified by the QB logo on the product. The certified characteristics are as follows:

- dimensional characteristics (see § 2.2.4 and 2.2.6),
- determination of simple compressive strength in the vertical direction on a block (see § 2.2.7.1.1).

As part of QB certification, the CSTB periodically audits manufacturing sites to examine the quality system in place, and takes and performs the following tests at the brand's laboratory by sampling a module (figure 1):

- dimensional characteristics,
- mechanical strength in simple compression.
- characterization of flexural modulus at 500h.

---

## 2.8. Mention of supporting documents

---

### 2.8.1. Experimental results

AQUABOX HP products have undergone the following tests:

- 500-hour creep test: CSTB EAU 22-10267-2,
- Simple short-term compression tests: EAU\_22\_10267\_1 and EAU\_23-22353 by CSTB,
- Additional short-term compression tests: ECAM 20RP02170 (stacking), Technoprove 277 /3/01I (non-rigid load) and CSTB EAU\_23-220455 (slope),

- Material tests: 2200021CAI, 2200101CAI, 2200022CAI, 2200023CAI, 2200073CRI from KIWA
- Long-term resistance tests carried out in-house with CSTB supervision at launch and during testing.

### **2.8.2. Site references**

An indicative list of references has been submitted to CSTB.

**2.9. Technical File Appendix**



**Figure 1 - AQUABOX HP module**

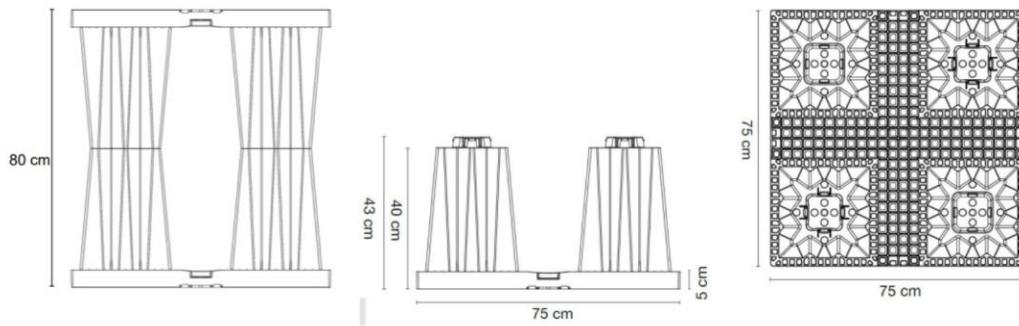

**Figure 2 - AQUABOX HP dimensional characteristics**

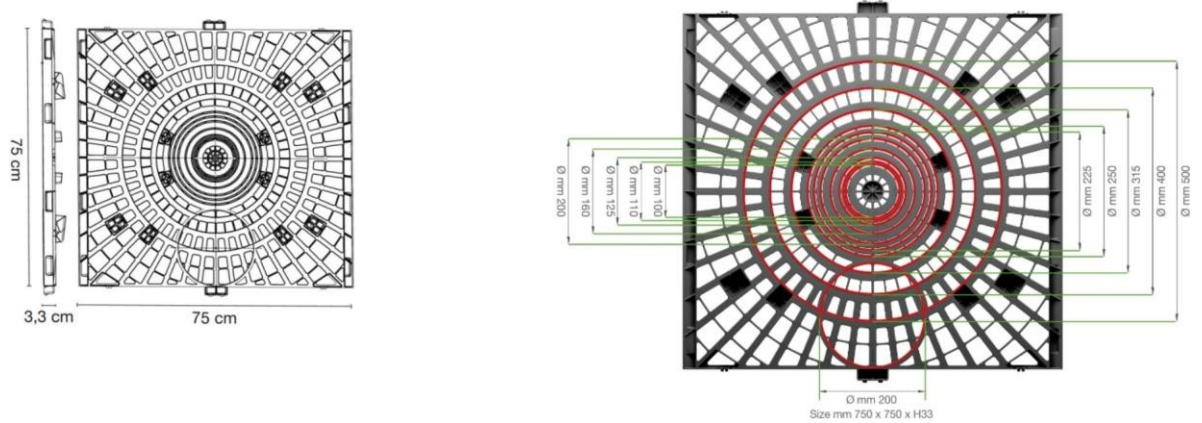

**Figure 3 - HPR side plate**

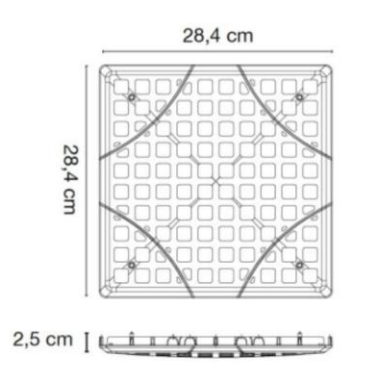

**Figure 4 - HPR top plate**

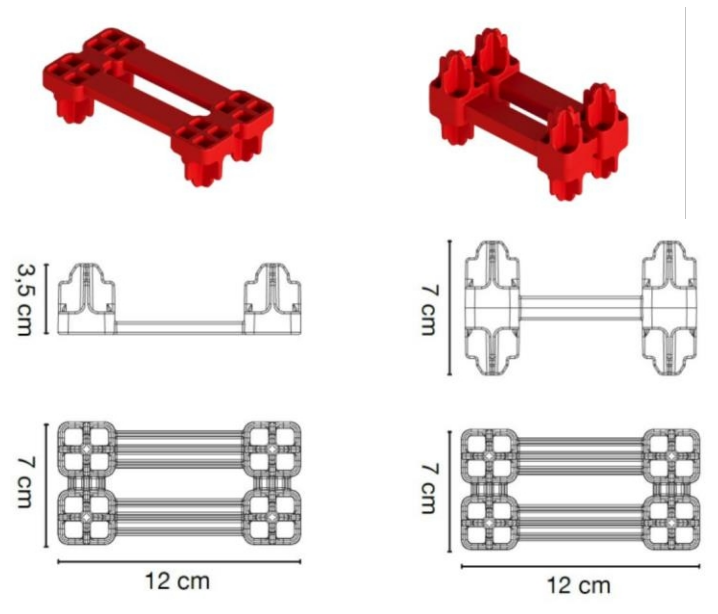

**Figure 5: Connectors (single on left; double on right)**

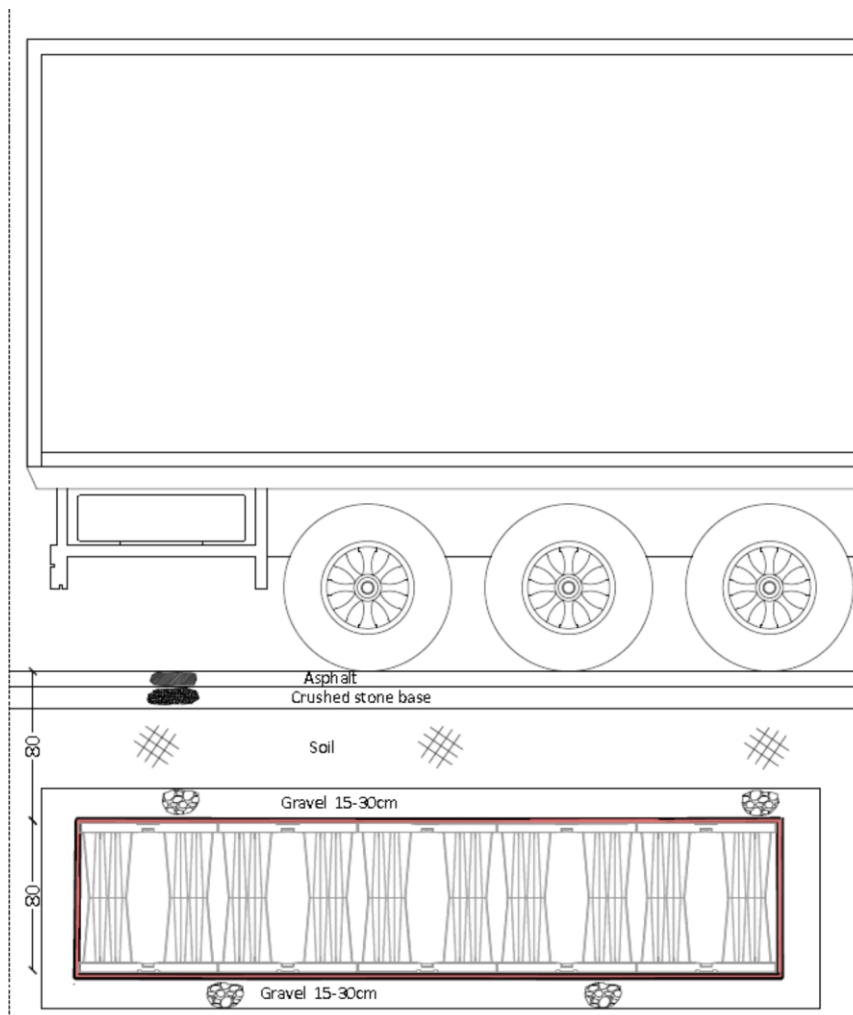

**Figure 6 - Cross-section of an AQUABOX HP basin**